

AUT

Y-strainer DIN3202-F1
PN6 / PN10 / PN16 / PN25

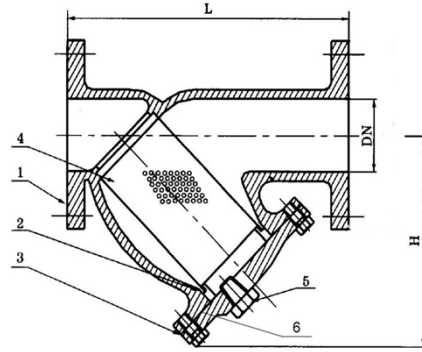

Parts

No.	Parts name	Material	Standards	Grade	Test				
					Nominal Pressure	PN6	PN10	PN16	PN25
1	Body	Ductile iron	DIN 1693	GGG50	Shell pressure	10	15	24	37.5
2	Collar	Ductile iron	DIN 1693	GGG50	Seat pressure	7.6	11	17.6	27.5
3	Cover	Ductile iron	DIN 1693	GGG50	Max .Temp	70 °C			
4	Screen	Stainless steel	DIN 17440	X5CrNi189					
5	Plug	Ductile iron	DIN 1693	GGG50					
6	Gasket	Graphite							

Designs

1	Design according to DIN 3356
2	Flange face to face according to DIN 3202 - F1
3	Flanged drilled according to DIN 2531-PN6 / DIN 2532-PN10 / DIN 2533-PN16 / DIN 2533 PN25
4	Inspection and test according to DIN 3230
5	Internal and external coating by fusion bonded epoxy powder 250 micron thickness

Dimensions

	Unit : mm															
DN	15	20	25	32	40	50	65	80	100	125	150	200	250	300	350	400
L	130	150	160	180	200	230	290	310	350	400	480	600	730	850	980	1100
H	90	100	110	125	140	160	185	200	225	280	360	440	525	585	670	750
Working pressure:PN6																
Dia.of flange	80	90	100	120	130	140	160	190	210	240	265	320	375	440	490	540
Nos.of hole	4	4	4	4	4	4	4	4	4	8	8	8	12	12	12	16
Dia.of hole	11.5	11.5	11.5	14	14	14	14	18	18	18	18	18	18	22	22	22
P.C.D	55	65	75	90	100	110	130	150	170	200	225	280	335	395	445	495
Working pressure:PN10																
Dia.of flange	95	105	115	140	150	165	185	200	220	250	285	340	395	445	505	565
Nos.of hole	4	4	4	4	4	4	4	4	8	8	8	8	12	12	16	16
Dia.of hole	14	14	14	18	18	18	18	18	18	18	22	22	22	22	22	26
P.C.D	65	75	85	100	110	125	145	160	180	210	240	295	350	400	460	515
Working pressure:PN16																
Dia.of flange	95	105	115	140	150	165	185	200	220	250	285	340	405	460	520	580
Nos.of hole	4	4	4	4	4	4	4	8	8	8	8	12	12	12	16	16
Dia.of hole	14	14	14	18	18	18	18	18	18	18	22	22	26	26	26	30
P.C.D	65	75	85	100	110	125	145	160	180	210	240	295	355	410	470	525
Working pressure:PN25																
Dia.of flange	95	105	115	140	150	165	185	200	235	270	300	340	405	460	520	580
Nos.of hole	4	4	4	4	4	4	4	8	8	8	8	12	12	12	16	16
Dia.of hole	14	14	14	18	18	18	18	18	23	27	27	22	26	26	26	30
P.C.D	65	75	85	100	110	125	145	160	190	220	300	360	425	485	555	620

AUT RESOURCES SDN BHD (768928D)
 43 GREEN DRIVE 11600 PENANG MALAYSIA
 PHONE : 60124210032, 60124238009 FAX : 6046439708
 E-mail : access_ustrade@yahoo.com. / write2us@autresources.com
<http://www.autresources.com/>