

AUT

Resilient Seat Foot Valve PN10 / PN16 / PN25
(Flanged End)

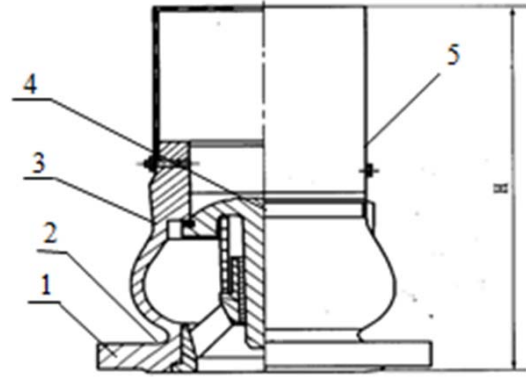

Parts

Test

No.	Parts name	Material	Standard	Grade	Normal pressure	PN10	PN16	PN25
1	Body	Ductile Iron	BS 2789	500/7	Shell pressure	15bars	24bars	37.5bars
2	Cover	Ductile iron	BS 2789	500/7	Seat pressure	11bars	17.6bars	27.5bars
3	Disc Seat	Synthetic Rubber	BS 2494	EPDM	Max .Temp	70 °C		
4	Disc	Ductile iron	BS 2789	500/7				
5	Strainer	Stainless Steel	BS 970 - part 1	431S29				

Designs

1	Design according to BS, DIN standard.
2	Flange drilled according to BS 4504 / JIS B2212 PN10, PN16, PN25
3	Inspection and test according to BS 6755
4	Internal and external coating by fusion bonded epoxy powder 250 micron thickness

Dimensions

Unit : mm

DN	H	Dimensions of Flange (PN10 / PN16 / PN25)			
		Dia. of flange	Nos. of hole	Dia. of hole	P.C.D.
		PN10 / PN16 / PN25	PN10 / PN16 / PN25	PN10 / PN16 / PN25	PN10 / PN16 / PN25
50	166	165 / 165 / 165	4 / 4 / 4	18 / 18 / 18	125 / 125 / 125
65	201	185 / 185 / 185	4 / 4 / 8	18 / 18 / 18	145 / 145 / 145
80	221	200 / 200 / 200	8 / 8 / 8	18 / 18 / 18	160 / 160 / 160
100	265	220 / 220 / 235	8 / 8 / 8	18 / 18 / 23	180 / 180 / 190
125	300	250 / 250 / 270	8 / 8 / 8	18 / 18 / 28	210 / 210 / 220
150	360	285 / 285 / 300	8 / 8 / 8	22 / 22 / 28	240 / 240 / 250
200	568	340 / 340 / 360	8 / 12 / 12	22 / 26 / 28	295 / 295 / 310
250	580	395 / 405 / 425	12 / 12 / 12	22 / 26 / 31	350 / 355 / 370
300	653	445 / 460 / 485	12 / 12 / 16	22 / 26 / 31	400 / 410 / 430

AUT RESOURCES SDN BHD (768928D)
 43 GREEN DRIVE 11600 PENANG MALAYSIA
 PHONE : 60124210032, 60124238009 FAX : 6046439708
 E-mail : access_ustrade@yahoo.com. / write2us@autresources.com
<http://www.autresources.com/>